

SOLUTION

SHEARS



GSII / GXII



UNIVERSAL SHEET METAL SHEARS



AMADA

GSII / GXII

UNIVERSAL SHEET METAL SHEARS

A COMPLETE RANGE OF DURABLE, RELIABLE AND EASY TO USE PRECISION TOOLS

THE EXPERTISE OF A LARGE-SCALE MANUFACTURER

It is crucial that the flow of blanks, the starting point for the entire manufacturing process, is managed with utmost quality and speed.

These two criteria are entrenched in the design and manufacture of AMADA's GS II and GX II sheet metal shears.

The rigidity of the frame, as well as the drive and adjustment solutions, ensure an exceptional degree of reliability and safety of use.

Beyond the technical considerations, these machines were developed with an improvement in working conditions, safety, ergonomics and aesthetics in mind.



Non-binding photo

MAIN FEATURES

1 CUTTING QUALITY, RELIABILITY AND PRECISION

RIGID STRUCTURE AND SOLID DRIVES

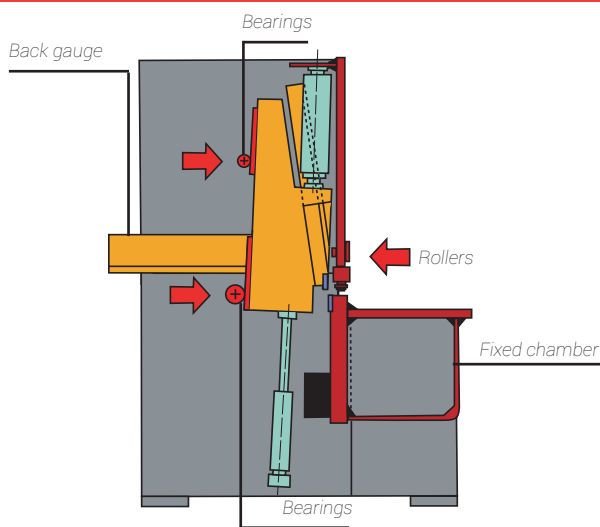

FIXED CHAMBER

The fixed chamber provides a consistent gap between the blades, which means that the structure keeps its shape. The door blade is driven by two sets of roller bearings. The 2°-inclination from the upper blade bracket gives the blade the ideal angle of attack.

MOTORISED BACK GAUGE

The high-precision back gauge with ball screw moves at 100 mm/s and has a positioning accuracy of 0.1 mm (0.05 mm repeatability).

You can program the crossbeam of the back gauge to retract, avoiding shearing actions that are anything other than precise.

EFFECTIVE SHEET METAL CLAMPS

The clamps use pressure which is proportional to the cutting force; they are equipped with polyurethane pads and apply even pressure to ensure optimum clamping results without marking the product, regardless of the raw material thickness.

2 EASE OF USE

FAST START-UP

EASY ADJUSTMENT

You can easily set the gap between the blades and the cutting angle by using levers on the GS II model. This is automatic on the GX II model based on the stroke width you enter on the keypad.

A system of optical viewfinders assists in alignment of the raw material.



EASY PROGRAMMING

The AMADA keypad was designed with the user in mind. Equipped with a touchscreen, it automatically manages all the cutting parameters. With a 50-program memory, it avoids all positioning errors by the blade bracket or back gauge. The keypad can be pivoted up to 90° so the operator can see the program sequence.



3 COMFORT AND ERGONOMICS

ACCESSORIES AND OPTIONS

ERGONOMIC FRONT WORKBENCH

Designed to help mount the numerous optional accessories such as bracket rails, front brackets with or without micrometric stop.

There are two types of workbench:

- Smooth bench as standard on the GS II
- Beaded bench as standard on the GX II (optional on the GS II)



MAINTAINING THE SHEET METAL AND SPILLWAY

The machine can be upgraded with an optional pneumatic sheet support or a belted spillway with sheet support and scrap collector.



DIMENSIONS

Unit: mm

GS II /GX II 630

(W) 3790 x (D) 2250 x (H) 1866

GS II /GX II 1230

(W) 3850 x (D) 2390 x (H) 2040

GS II /GX II 840

(W) 4810 x (D) 2510 x (H) 2040

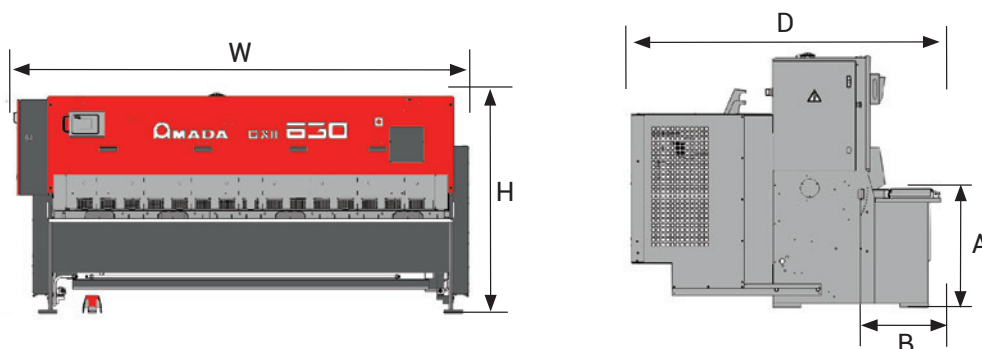

MACHINE SPECIFICATIONS

MODELS			GS II / GX II 630	GS II / GX II 1230	GS II / GX II 840
Cutting length		mm	3050	3050	4050
Maximum thickness	Steel 450 MPa/mm ²	mm	6	12	8
	Stainless steel 600 MPa/mm ²	mm	4	8	6
	Aluminium 300 MPa/mm ²	mm	8	14	10
Cutting angle	Minimum		40'	40'	40'
	Maximum		2°20'	2°50'	2°10'
Speed	Length and minimum angle	hits/min	24	22	19
	Length and maximum angle	hits/min	13	11	11
Maximum speed	Length 100 mm and maximum angle	hits/min	33	29	29
Back gauge carriage		mm	1000		
Back gauge speed		mm/s	100		
Number of sheet metal clamps			16		21
Number of stainless steel shelves on the worktop			4		5
Block	Depth with spillway	mm	3250		
	Worktop height (A)	mm	860		
	Worktop depth (B)	mm	575		700
Power		kVA	6		16

For the purpose of improvement, the elements contained in this brochure are subject to change.



For your safety, carefully read the manual before using the machine.

The wearing of personal protective equipment is compulsory for the use of this machine.

The official name of the machine described in this brochure is GS/GX. Please use this name at all requests for installation, export and funding.

Safety devices have been removed in some photos used in this brochure.

AMADA UK LTD.

Spennells Valley Road,
Kidderminster,
Worcestershire DY10 1XS
United Kingdom
Tel: +44 (0)1562 749500
Fax: +44 (0)1562 749510
www.amada.co.uk

AMADA SA

Paris Nord II
96, avenue de la Pyramide
93290 Tremblay en France
France
Tél : +33 (0)1 49 90 30 00
Fax : +33 (0)1 49 90 31 99
www.amada.fr

AMADA GmbH

Amada Allee 1
42781 Haan
Germany
Tel: +49 (0)2104 2126-0
Fax: +49 (0)2104 2126-999
www.amada.de

AMADA ITALIA S.r.l.

Via Amada I., 1/3
29010 Pontenure
(Piacenza)
Italia
Tel: +39 (0)523 872111
Fax: +39 (0)523 872101
www.amada.it

